

Koła łańcuchowe z piastą

链轮 SPROCKET

1"1/2 x 1"

24B-1-2-3, ~24A-1-2-3

链轮 SPROCKET 1"1/2 x 1"

配对链条标准为DIN8187 ISO/R 606
For Chain Acc.to DIN8187 ISO/R 606

链轮 SPROCKET	mm
齿侧倒角半径 Tooth Radius r3	38.0
齿侧倒角宽 Radius Width C	4.0
齿宽 Tooth Width B1	24.1
齿宽 Tooth Width b1	23.6
齿宽 Tooth Width B2	72.0
齿宽 Tooth Width B3	120.3

链条 CHAIN	mm
节距 Pitch	38.1
内节内宽 Internal Width	25.4
滚子直径 Roller Diameter	25.4

*为焊接凸台 *Welding hub

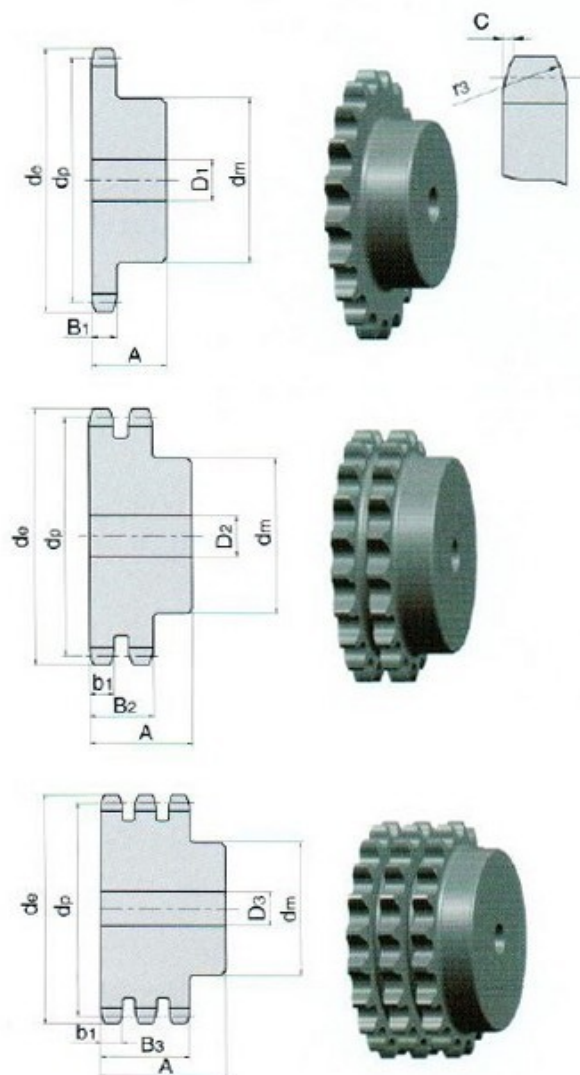

Z	de	dp	SIMPLEX			DUPLEX			TRIPLEX		
			dm	D1	A	dm	D2	A	dm	D3	A
8	115.0	90.55	58	20	45	58	25	95	58	25	140
9	126.4	111.40	70	20	45	70	25	95	70	25	140
10	138.0	123.29	80	20	45	80	25	95	80	25	140
11	150.0	135.21	90	25	50	90	25	100	90	25	150
12	162.0	147.22	102	25	50	102	25	100	102	25	150
13	174.2	159.18	114	25	50	114	25	100	114	25	150
14	186.2	171.22	128	25	50	128	25	100	128	25	150
15	198.2	183.26	132	25	50	132	25	100	132	25	150
16	210.3	195.30	*136	25	55	*136	25	100	136	25	150
17	222.3	207.34	*136	25	55	*136	25	100	140	25	150
18	234.3	219.42	*136	25	55	*150	25	100	*150	25	150
19	246.5	231.49	*136	25	55	*160	25	100	*160	25	150
20	258.6	243.57	*136	25	55	*160	25	100	*160	25	150
21	270.6	255.65	*150	25	60	*160	25	100	*160	30	150
22	282.7	267.73	*150	25	60	*160	25	100	*160	30	150
23	294.8	279.80	*150	25	60	*160	25	100	*160	30	150
24	306.8	291.88	*150	25	60	*160	25	100	*160	30	150
25	319.0	304.00	*150	25	60	*160	25	100	*160	30	150
26	331.0	316.08	*150	30	60	*160	30	100	*160	30	150
27	343.2	328.19	*150	30	60	*160	30	100	*160	30	150
28	355.2	340.27	*150	30	60	*160	30	100	*160	30	150
29	367.3	352.38	*150	30	60	*160	30	100	*160	30	150
30	379.5	364.50	*150	30	60	*160	30	100	*160	40	150
31	391.6	376.62	*150	30	60	*160	30	100	*160	40	150
32	403.7	388.69	*150	30	60	*160	30	100	*160	40	150
33	415.8	400.81	*150	30	60	*160	30	100	*160	40	150
34	427.8	412.93	*150	30	60	*160	30	100	*160	40	150
35	440.0	425.04	*150	30	60	*160	30	100	*160	40	150
36	452.0	437.16	*150	30	60	*160	30	100	*160	40	150
37	464.2	449.27	*150	30	60	*160	30	100	*160	40	150
38	476.2	461.39	*150	30	60	*160	30	100	*160	40	150
39	488.5	473.50	*150	30	60	*160	30	100	*160	40	150
40	500.6	485.62	*150	30	60	*160	30	100	*160	40	150
41	512.6	497.72	*160	30	90	*180	30	100	*200	40	150
42	524.7	509.83	*160	30	90	*180	30	100	*200	40	150
43	536.8	521.95	*160	30	90	*180	30	100	*200	40	150
44	549.0	534.07	*160	30	90	*180	30	100	*200	40	150
45	561.2	546.19	*160	30	90	*180	30	100	*200	40	150
46	573.3	558.30	*160	30	90	*180	30	100	*200	40	150
47	585.4	570.42	*160	30	90	*180	30	100	*200	40	150
48	597.4	582.54	*160	30	90	*180	30	100	*200	40	150
49	609.5	594.66	*160	30	90	*180	30	100	*200	40	150
50	621.7	606.78	*160	30	90	*180	30	100	*200	40	150
51	633.8	618.90	*160	30	100	*180	30	110	*200	40	150
52	646.0	631.01	*160	30	100	*180	30	110	*200	40	150
53	658.0	643.13	*160	30	100	*180	30	110	*200	40	150
54	670.2	655.28	*160	30	100	*180	30	110	*200	40	150
55	682.3	667.40	*160	30	100	*180	30	110	*200	40	150
56	694.4	679.51	*160	30	100	*180	30	110	*200	40	150
57	706.5	691.63	*160	30	100	*180	30	110	*200	40	150
58	718.6	703.74	*160	30	100	*180	30	110	*200	40	150
59	730.7	715.86	*160	30	100	*180	30	110	*200	40	150
60	742.8	727.97	*160	30	100	*180	30	110	*200	40	150
62	767.2	752.24	*160	30	100	*180	30	110	*200	40	150
64	791.3	776.48	*160	30	100	*200	30	110	*220	40	150
65	803.4	788.59	*160	30	100	*200	30	110	*220	40	150
66	815.6	800.71	*160	30	100	*200	30	120	*220	40	150
68	839.8	824.98	*160	30	100	*200	30	120	*220	40	150
70	864.2	849.21	*160	30	100	*200	30	120	*220	40	150
72	888.4	873.48	*160	30	100	*200	30	120	*220	40	150
75	924.8	909.83	*160	30	100	*200	30	120	*220	40	150
76	936.9	921.98	*160	30	100	*200	30	120	*220	40	150
80	985.4	970.44	*160	30	100	*200	30	120	*220	40	150
85	1046.0	1031.10	*160	30	100	*200	30	120	*220	40	150
90	1167.3	1152.33	*160	30	100	*200	30	120	*220	40	150